

CLASSICAL COURTYARD LIGHT SERIES SPECIFICATION



Features

- Features a combination of security, style and vandal resistance that lightens pathways beautifully. Special
- heat dissipation design to achieve optimum efficiency.
- High-shock and high-vibration resistant. Color temperature offering of 3000K(Warm White), 4000K(Natural White) and 5000K(Cool White).
- Green, energy saving, long and reliable life of 50,000 hours.
- Conforms to the strictest approval standards. ETL approved for wet or damp locations.
- Application: Main road, Rural road, commercial square, Garden, Villa, etc...

Advantage

- Easy and secure installation
- Ideal for Harsh Environment Applications
- Uniformity lighting distribution
- High lumens efficiency and high CRI
- Environmentally friendly with no mercury

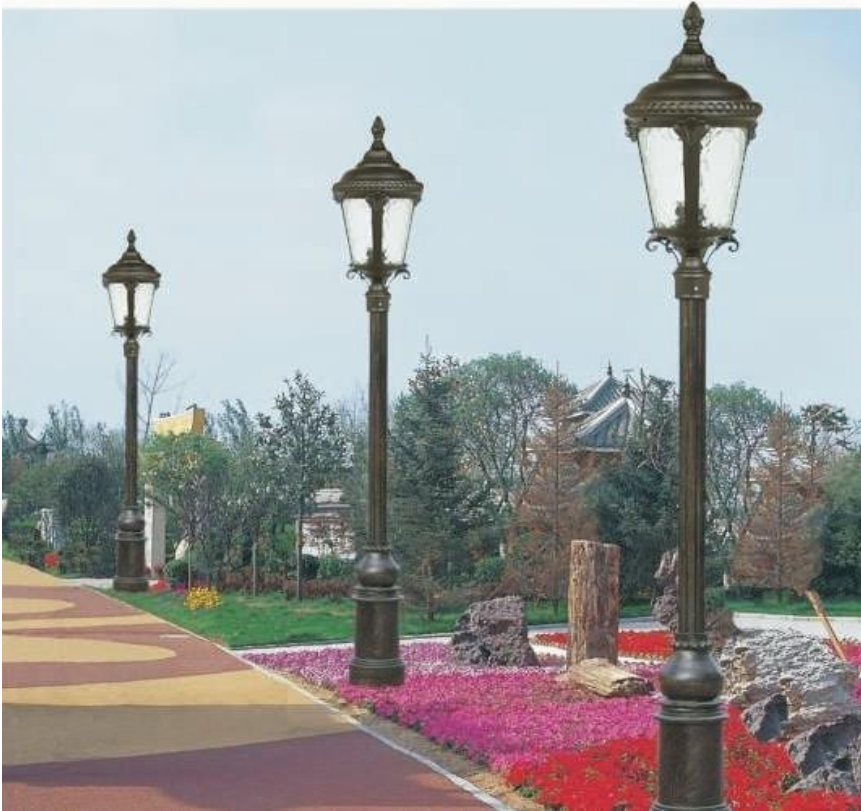

Description

Die-casting housing

Basic Feature

No: OGLD01

E26, Max. 100W or PLC 23W

Water Glass

Class I, IP44

Light Distribution

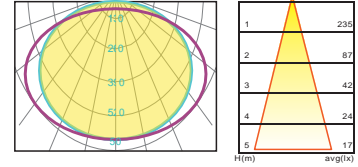

Dimension

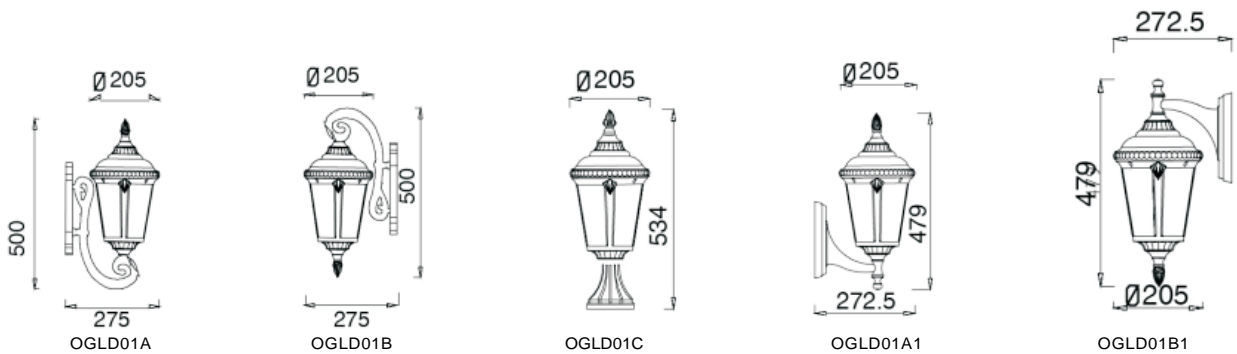

Classical
Courtyard Light Series



Dimension

